

11+ Kent Maths, English Practice Papers

✓ 4 Kent Practice Paper Packs

✓ 600+ Kent Style MCQs

✓ Detailed Answer & Hints

✓ Mirrors Real Exam Pattern



11+ Kent

Paper 1 - Session 2

Instructions:

1. Do not turn over this page until instructed to do so.
2. This test contains two sections:
 - Test 1: **English**
 - Test 2: **Maths**
3. The front page of each test contains specific instructions. Read them carefully before starting.
4. Listen carefully to the instructions read out by the invigilator. They will guide you through the test process.
5. Check that your name and date of birth are correctly shown on the answer sheet.
6. In the answer sheet, mark the correct answer by drawing a line with your pencil through the small rectangular box beside it like this.
7. You must make sure that you mark your answer in the box that has the same question number as the question you are doing in the test booklet.
8. If you make a mistake, rub out your mark as well as you can and mark your new answer.
9. The answer sheet will be marked by a computer.
10. You may do any rough work in the question paper.
11. This is a multiple-choice test. Each question carries 1 mark.
12. At the bottom of each page in the test paper are instructions mentioned below telling you:

to stop:

Do not turn the page until told to do so 

to go on:

Please go on to the next page >>>

or whether you have reached the end of the section/test.

END OF TEST

11+ Kent

Paper 1 - Test 1

English

Instructions:

1. Do not turn over the page until instructed to do so.
2. The test begins with a **5-minute practice section**.
3. The practice section consists of:
 - **Two reading comprehension** questions.
 - **Cloze questions, spelling/grammar/punctuation**, with an example question followed by practice questions.
4. The practice section is followed by the main questions.
5. Total time for the main test is **25 minutes**, with **25 questions**.
6. Work quickly and carefully through the questions.
7. If you finish early, go back and check your work.
8. This is a **multiple-choice test**. Each question carries **1 mark**.



English: Practice Section (5 mins)

Reading Comprehension

Read this passage carefully, then answer the questions that follow.

At the Bay

1. “Wait for me, Isabel! Kezia, wait for me!”

There was poor little Lottie, left behind again, because she found it so fearfully hard to get over the stile by herself. When she stood on the first step her knees began to wobble; she grasped the post. Then you had to put one leg over. But which leg? She never could decide. And when she did finally put one leg over with a sort of stamp of despair - then the feeling was awful. She was half in the paddock still and half in the tussock grass. She clutched the post desperately and lifted up her voice. “Wait for me!”

5. “No, don’t you wait for her, Kezia!” said Isabel. “She’s such a little silly. She’s always making a fuss. Come on!” And she tugged Kezia’s jersey. “You can use my bucket if you come with me,” she said kindly. “It’s bigger than yours.”



Read the above practice passage carefully and answer the following questions. Mark the correct answer on the provided answer sheet by choosing one of the options from A-E.

1 How does Isabel feel about waiting for Lottie?

- A** She is patient and willing to wait.
- B** She is sympathetic towards Lottie.
- C** She is annoyed and dismissive.
- D** She is indifferent and bored.
- E** She feels guilty for leaving her behind.

2 Which sentence from the passage shows Isabel trying to persuade Kezia to leave Lottie behind?

- A** "Wait for me, Isabel! Kezia, wait for me!"
- B** "She clutched the post desperately and lifted up her voice."
- C** "She's always making a fuss."
- D** "You can use my bucket if you come with me," she said kindly.
- E** "She grasped the post."



In the following sentences, on each line there is either one capital letter or punctuation mistake, or there is no mistake. Find the group of words with the mistake in it and mark its letter on the answer sheet.

Example

She couldnt believe how quickly the time had passed.

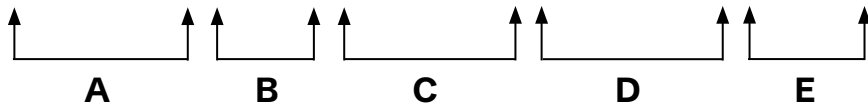

The answer is **A** because **"couldn't" requires an apostrophe** to correctly form the contraction of **"could not."** The apostrophe replaces the missing letter **"o"** in **"not."** **None of the other words in the sentence require punctuation corrections, making A the only valid answer.**

Now try the practice question below. Work out the correct answer and mark it on the answer sheet.

3

Wow That was an incredible goal.

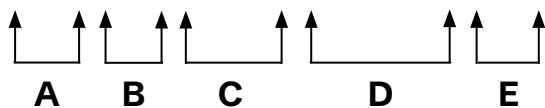



In the following sentences, on each line there is either one spelling mistake or none. Find the group of words with the mistake in it and mark its letter on the answer sheet. If there is no mistake, mark 'N'.

Example

The dog waged its tail excitedly as it ran toward its owner.

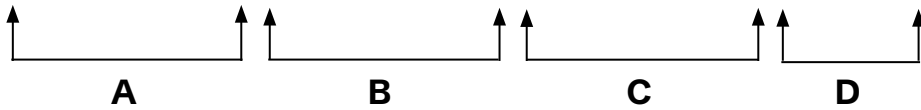

The answer is A because "waged" is incorrect in this context. The correct word should be "wagged," as the sentence describes a dog moving its tail back and forth. "Waged" means to carry out or engage in (e.g., "He waged a war"), which does not make sense here. The rest of the sentence is correct, so A is the only valid answer.

Now try the practice question below. Work out the correct answer and mark it on the answer sheet.

4

The elephant is the largest land animal, and is truely an amazing creature.

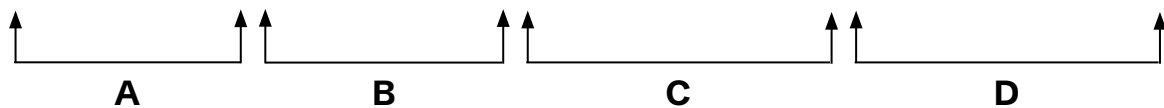



Identify the best word or group of words to complete the following sentences, so that it makes sense and is written in correct English. You should choose one of the following answers (A - E) and mark its letter on the answer sheet.

Example

The children raced the field to catch the flying kite.

A **B** **C** **D** **E**

*The answer is **A** because **across** is the preposition that makes the best sense in the sentence as a whole. "Across" specifically describes motion from one end to the other, which matches the action of racing to catch something. "Through" would imply moving within a confined space (e.g., a forest), "under" suggests below the field (illogical), "above" means overhead (not ground movement), and "around" indicates circling rather than crossing. Therefore **across**, option **A** is the only valid answer.*

Now try the practice questions below. Work out the correct answer and mark it on the answer sheet.

5

During their camping trip, Emma realised she had

A **B**

her sleeping bag at home.

C **D** **E**



6

He couldn't find his keys anywhere and he knew he

A**B****C****D****E**

left them at home.

This is the end of the English practice section.





English

You have **25 minutes to complete** this section. There are **25 questions**.
This section is **marked**.

Reading Comprehension

Read this passage carefully, then answer the questions that follow.

Jane Eyre

In this passage, the protagonist Jane has recently started a new school. This passage describes the hectic routine of a day at the school.

1. The night passed rapidly: I was too tired even to dream; I only once awoke to hear the wind rave in furious gusts, and the rain fall in torrents, and to be sensible that Miss Miller had taken her place by my side. When I again unclosed my eyes, a loud bell was ringing; the girls were up and dressing; day had not yet begun to dawn,
5. and a rushlight or two burned in the room. I too rose reluctantly; it was bitter cold, and I dressed as well as I could for shivering, and washed when there was a basin at liberty, which did not occur soon, as there was but one basin to six girls, on the stands down the middle of the room. Again the bell rang: all formed in file, two and two, and in that order descended the stairs and entered the cold and dimly lit
10. schoolroom: here prayers were read by Miss Miller; afterwards she called out—
“Form classes!”

- A great tumult succeeded for some minutes, during which Miss Miller repeatedly exclaimed, “Silence!” and “Order!” When it subsided, I saw them all drawn up in four semicircles, before four chairs, placed at the four tables; all held books in their
15. hands, and a great book, like a Bible, lay on each table, before the vacant seat. A pause of some seconds succeeded, filled up by the low, vague hum of numbers; Miss Miller walked from class to class, hushing this indefinite sound.



- A distant bell tinkled: immediately three ladies entered the room, each walked to a table and took her seat; Miss Miller assumed the fourth vacant chair, which was that
20. nearest the door, and around which the smallest of the children were assembled: to this inferior class I was called, and placed at the bottom of it.
- Business now began: the day's Collect was repeated, then certain texts of Scripture were said, and to these succeeded a protracted reading of chapters in the Bible, which lasted an hour. By the time that exercise was terminated, day had fully
25. dawned. The indefatigable bell now sounded for the fourth time: the classes were marshalled and marched into another room to breakfast: how glad I was to behold a prospect of getting something to eat! I was now nearly sick from inanition, having taken so little the day before.
- The refectory was a great, low-ceiled, gloomy room; on two long tables smoked
30. basins of something hot, which, however, to my dismay, sent forth an odour far from inviting. I saw a universal manifestation of discontent when the fumes of the repast met the nostrils of those destined to swallow it; from the van of the procession, the tall girls of the first class, rose the whispered words—
- “Disgusting! The porridge is burnt again!”
35. “Silence!” ejaculated a voice; not that of Miss Miller, but one of the upper teachers, a little and dark personage, smartly dressed, but of somewhat morose aspect, who installed herself at the top of one table, while a more buxom lady presided at the other. I looked in vain for her I had first seen the night before; she was not visible: Miss Miller occupied the foot of the table where I sat, and a strange, foreign-looking,
40. elderly lady, the French teacher, as I afterwards found, took the corresponding seat at the other board. A long grace was said and a hymn sung; then a servant brought in some tea for the teachers, and the meal began.



Read the above passage carefully and answer the following questions. Mark the correct answer on the provided answer sheet by choosing one of the options from A-E.

1

What does the word "inanition" mean in the context of the passage?

- A** Excitement
- B** Hunger
- C** Sleepiness
- D** Confusion
- E** Fatigue

2

Which of the following best describes the room when the girls are getting ready in the morning?

- A** Well-lit and warm
- B** Poorly lit with a rushlight or two
- C** Spacious and luxurious
- D** Fully heated
- E** Dimly lit and cosy



3

Why were the girls unhappy with their breakfast?

- A The food was served cold.
- B There was not enough food.
- C The porridge was burnt.
- D They disliked eating in silence.
- E Breakfast was served late.

4

What mood is created by the lines: "The night passed rapidly"?

- A Restless and hurried
- B Exhausted and slow
- C Uneventful and neutral
- D Tense and suspenseful
- E Drowsy and dreamlike

**5**

What can we infer about the narrator's feelings toward the school based on the passage?

- A** The narrator feels excited about the new educational opportunity.
- B** The narrator feels uncomfortable and overwhelmed by the strict regimen.
- C** The narrator feels neutral about the school environment.
- D** The narrator appreciates the structured routine of the school.
- E** The narrator feels relieved to be away from a previous situation.

6

What is the significance of the phrase "a rushlight or two burned in the room"?

- A** It emphasises the warmth of the room.
- B** It shows that the room is poorly lit.
- C** It suggests the girls are ready for the day.
- D** It creates a peaceful atmosphere.
- E** It foreshadows something important.

7

Which of the following is an example of personification in the passage?

- A** "The wind rave in furious gusts"
- B** "A loud bell was ringing"
- C** "The girls were up and dressing"
- D** "The room smelled of porridge"
- E** "The moon set over the hill"



8 What is the first activity after the bell rings for the second time?

- A** The girls form in file, two by two
- B** Prayers are read by Miss Miller
- C** The girls march to the refectory
- D** The Bible chapters are read
- E** The girls wash and dress

9 Why does the narrator describe the food at breakfast as "disgusting"?

- A** The food is too cold to eat.
- B** The food is poorly prepared and unappetising.
- C** The narrator dislikes food in general.
- D** The girls are in a bad mood due to lack of sleep.
- E** The food is served in small portions.

10 Which sentence uses hyperbole?

- A** "The wind rave in furious gusts."
- B** "I was too tired even to dream."
- C** "The bell rang loudly"
- D** "The girls were up and dressing."
- E** "The room smelled of burning porridge."



11

What can we infer about Miss Miller from the phrase "Form classes!" and her actions?

- A She is very strict and authoritative.
- B She is new to the role and unsure.
- C She is kind and patient with the children.
- D She is distant and disengaged.
- E She is excited to begin the day.

12

What is the meaning of the word "refectory" in the passage?

- A A place of worship
- B A dormitory
- C A dining hall
- D A classroom
- E A storage room



13 What does the description of the breakfast scene reveal about the school's attitude toward the students?

- A** The school prioritises nutrition and student satisfaction.
- B** The school shows favouritism toward teachers over students.
- C** The school maintains a democratic approach to meals.
- D** The school emphasises religious practices over physical comfort and nourishment.
- E** The school allows students to express their opinions freely.



In the following sentences, on each line there is either one capital letter or punctuation mistake, or there is no mistake. Find the group of words with the mistake in it and mark its letter on the answer sheet.

14

“Are we going to the cinema tonight? asked Jake.

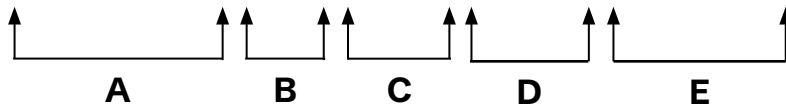

15

On monday morning, we have our weekly assembly in the hall.

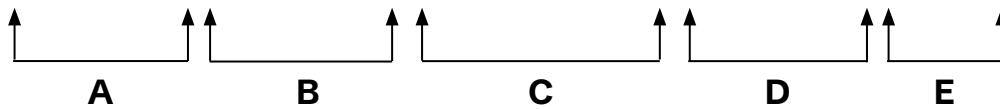

16

Its very important to bring your passport when travelling abroad.

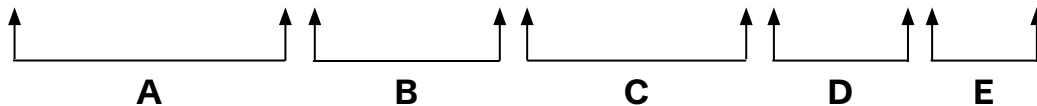



In the following sentences, on each line there is either one spelling mistake or none. Find the group of words with the mistake in it and mark its letter on the answer sheet. If there is no mistake, mark 'N'.

17

The magician performed an incredible trick in front of audience.

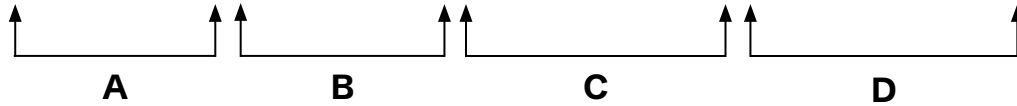

18

After exercising regularly, Tom noticed a definite improvement.

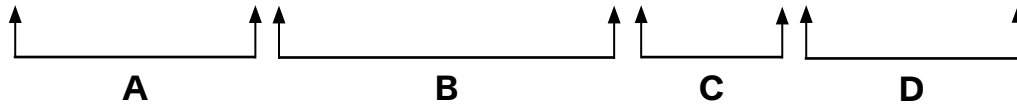

19

My neighbour received a bicycle as a birthday present.

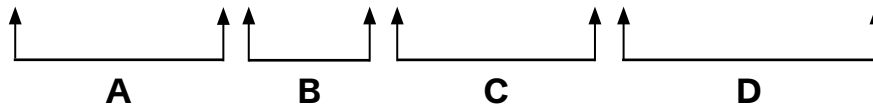

20

The teacher explained how the question could have been solved in an easier way.

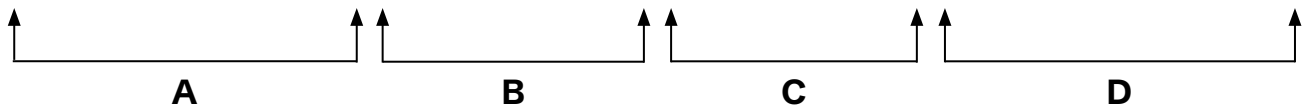



Identify the best word or group of words to complete the following sentences, so that it makes sense and is written in correct English. You should choose one of the following answers (A - E) and mark its letter on the answer sheet.

21 On the road trip, Sarah realised she had
A B C

the picnic basket.
D E

22 “We turn back to get it,” Dad
A B C D E

said firmly.

23 “If we go back now, we
A B C D

miss the sunset at the lake,” protested Jake.
E



24

Luckily, they still had of snacks

A **B** **C** **D** **E**

in the car to keep everyone happy.

25

“There’s reason to argue,” said

A **B** **C** **D** **E**

Mom. “Let’s enjoy the drive!”

11+ Kent

Paper 1 - Test 2

Maths

Instructions:

1. Do not turn over this page until instructed to do so.
2. The test begins with a **5-minute practice section**.
3. The practice section includes 4 questions.
 - The first question is solved as an example.
 - The remaining questions are for you to attempt.
4. The practice section is followed by the main questions.
5. Total time for the main questions is **25 minutes**.
6. Work quickly and carefully through the questions.
7. If you finish early, go back and check your work.
8. This is a **multiple-choice test**. Each question carries **1 mark**.



Maths: Practice Section (5 mins)

Example

Which of the following represents the longest distance?

- A** 875 metres **B** 65, 000 centimetres **C** 2, 015, 500 millimetres
D $1\frac{1}{4}$ kilometres **E** $\frac{7}{10}$ kilometres

Solution

Option C is correct

A 875 metres: (Already in metres)

B 65, 000 centimetres = $65, 000 \div 100 = 650$ metres

C 2, 015, 500 millimetres = $2, 015, 500 \div 1000 = 2015.5$ metres

D $1\frac{1}{4}$ kilometres = $1\frac{1}{4} = 1.25$ kilometres = $1.25 \times 1000 = 1250$ metres

E $\frac{7}{10}$ kilometres = $\frac{7}{10} \times 1000 = 700$ metres

2015.5 metres is the longest.



Now try the practice questions below. Work out the correct answer and mark it on the answer sheet.

1 Jenny's toy box is in the shape of a hexagonal prism, with its lid being the hexagonal face.

In how many ways can she rotate the lid so that it still fits the toy box?

A 2

B 3

C 4

D 5

E 6

2 Which of the following expressions gives the largest value?

A 50×3

B 1500

C 3×50^2

D 520

E 50×3^3

3 Sarah writes the following numbers:

1, 2, 3, 4, 5, 6, 7, 8, 10, 12, 15.

Which number from Sarah's list is not a factor of 120?

A 3

B 7

C 8

D 10

E 12

This is the end of the Maths practice section.



Maths

You have **25 minutes to complete** this section. There are **25 questions**. This section is **marked**.

1

John planted a tree when he was 8 years old. He passed away in the year 1950 at the age of 78.

How old was the tree in the year 2020?

- A** 142 years **B** 132 years **C** 140 years
D 128 years **E** 118 years

2

Anna is preparing 480 grams of fruit salad. She uses:

- 20% of the weight for bananas,
- 35% of the weight for apples,
- 25% of the weight for corn flour and milk,
- 5% of the weight for dried fruits.
- The rest of the weight is pineapple

How many grams of pineapple does she use?

- A** 96 g **B** 132 g **C** 72 g **D** 117 g **E** 216 g

3

A regular polygon has 44 diagonals.

How many sides does this polygon have?

- A** 11 **B** 9 **C** 8 **D** 12 **E** 10



4 Emma and Liam are drinking juice from the same bottle. The bottle contains 1500 ml of juice. Liam drinks 50% more than Emma.

How much juice does Emma drink if together they finish the entire bottle?

- A** 700 ml **B** 600 ml **C** 800 ml **D** 500 ml **E** 900 ml

5 Sophia is buying plates and cups for a party. Plates are sold in packs of 12, and cups are sold in packs of 16. She wants to buy the same number of plates and cups.

What is the minimum number of cups she can buy?

- A** 36 **B** 48 **C** 64 **D** 96 **E** 144

6 Mary, John, and Liam each own a different number of marbles. The average number of marbles with Mary and Liam is 72. The average number of marbles with John and Liam is 54. Together, they have a total of 198 marbles.

How many marbles does Mary have?

- A** 90 **B** 84 **C** 78 **D** 66 **E** 72



7 A painter earns according to the formula:
Earnings in £ = $1.5 \times$ number of walls painted in a day + 2.

If he painted 5 walls every day last week, what was his total pay for the week?

- A** £60.50 **B** £72.50 **C** £84.50 **D** £90.50 **E** £66.50

8 Check out the calculation below:

$$24500 \times ? = 245$$

What is the missing number?

- A** 0.1 **B** 0.101 **C** 0.01 **D** 1.01 **E** 0.001

9 The table below shows the ages of students in a class.

Name	Age
Liam	5 years 4 months
Sophia	4 years 6 months
Ella	6 years 2 months
Noah	4 years 9 months
Olive	7 years 1 months
Amelia	6 years 10 months

If the students are arranged in ascending order of their ages, who will be in the second position?

- A** Noah **B** Liam **C** Amelia **D** Oliver **E** Sophia



10 In a fruit bowl, there is 50% more apples than oranges.
What is the ratio of oranges to apples?

- A** 2 : 3 **B** 3 : 2 **C** 4 : 5 **D** 5 : 4 **E** 6 : 4

11 Which of these numbers is the largest?

- A** 30×5 **B** 3030 **C** 3×30^2
D $3^2 \times 5^2 \times 10$ **E** 30×5^2

12 In a group of 60 people, 40% like coffee, and 35% like tea.
One-sixth of the people like both items.

How many people do not like either of the items?

- A** 15 **B** 18 **C** 20 **D** 22 **E** 25



13 A shoe store recorded the sizes of shoes sold during the weekend:

5, 7, 6, 6, 8, 4, 5, 4, 7, 6, 5, 8.

What is the median shoe size?

- A** 5 **B** 6 **C** 7 **D** 4 **E** 8

14 A store sells candies at different prices. The cheapest candies in the store cost 15 p each.

Sophia has one £10 note and six £1 coins with her.

What is the maximum number of candies she can buy if she chooses the cheapest candies?

- A** 106 **B** 105 **C** 108 **D** 107 **E** 109

15 The first four terms of a sequence are:

2, 6, 12, 20.

What will the 7th term of this sequence be?

- A** 64 **B** 62 **C** 56 **D** 52 **E** 54



16

A large cube is painted on all six outer faces and then cut into 125 smaller cubes of equal size.

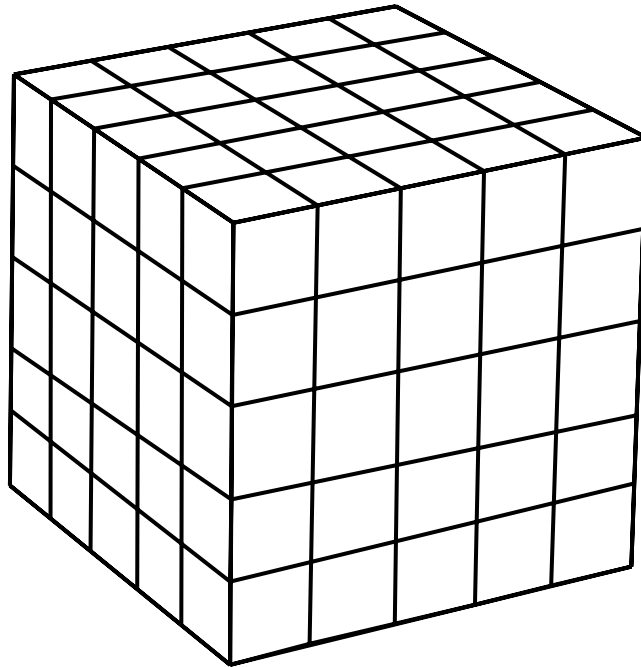

How many of the smaller cubes have exactly one faces painted?

- A** 12 **B** 15 **C** 24 **D** 60 **E** 54

17

A bookstore has the following offers on novels:

Offer A	Buy 2 Get 1 Free
Offer B	50% Off on all items

Emma buys 3 novels, each priced at £40.

What is the difference between the cost of these offers?

- A** £60 **B** £40 **C** £20 **D** £30 **E** £25



- 18 The bar graph below shows the weights of players at a football club.

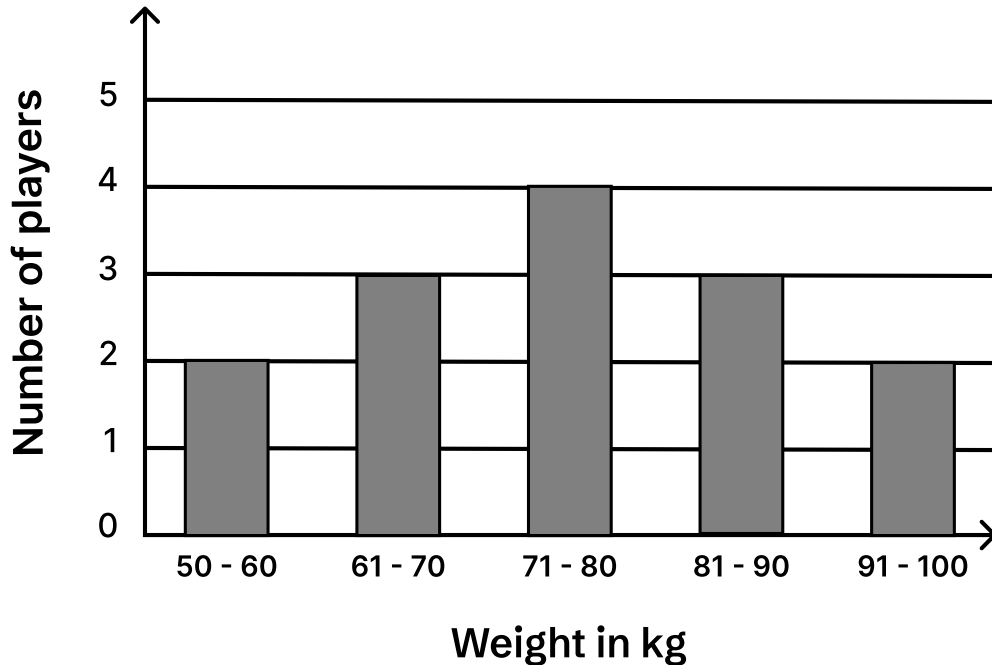

How many players have a weight of 80 kg or less?

- A 5 B 6 C 7 D 9 E 8

- 19 Emma spun a spinner 20 times. The frequency table below shows the outcomes of her spins.

Score	Frequency
1	4
2	6
3	3
4	7

What is the mean score rounded to one decimal place?

- A 2.9 B 2.7 C 3 D 2.8 E 3.1



20

The grid below shows a partially shaded figure.

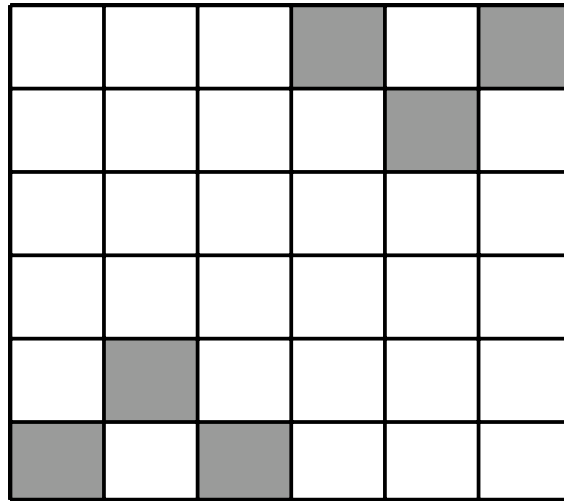

What is the smallest number of additional squares that must be shaded so that this figure has a rotational symmetry of order 2?

- A** 4 **B** 6 **C** 3 **D** 5 **E** 2

21

Calculate the area of the shaded region.

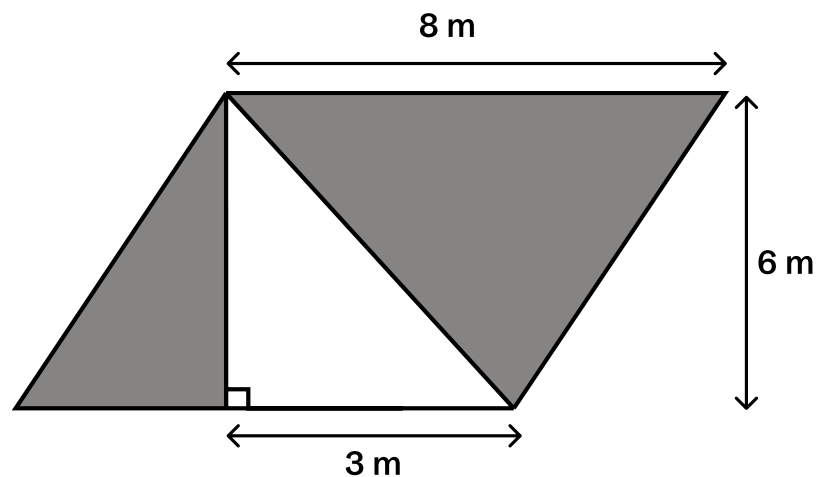

- A** 48 m^2 **B** 42 m^2 **C** 36 m^2
D 40 m^2 **E** 39 m^2

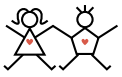

22

Here is a pattern made of some shapes.

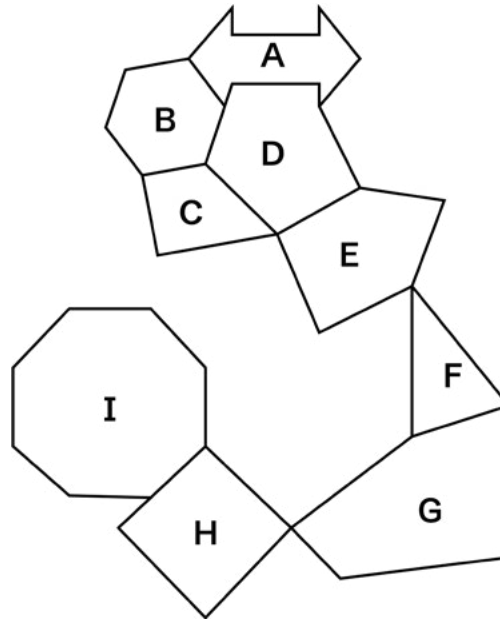

Write the letters of the two shapes which are pentagons.

A C, D**B** E, D**C** F, G**D** E, G**E** B, D

23

What is the order of rotational symmetry of the shape below?

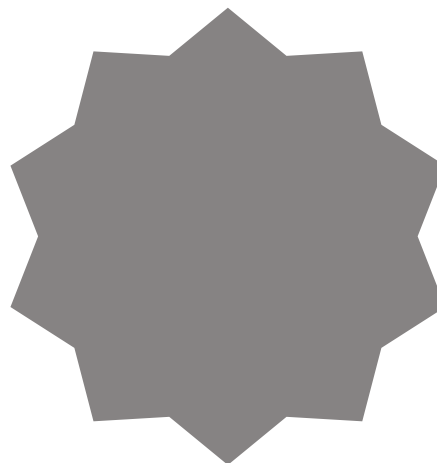
**A** 6**B** 4**C** 5**D** 2**E** 1



24

Work out the size of the angle marked y in the figure below.

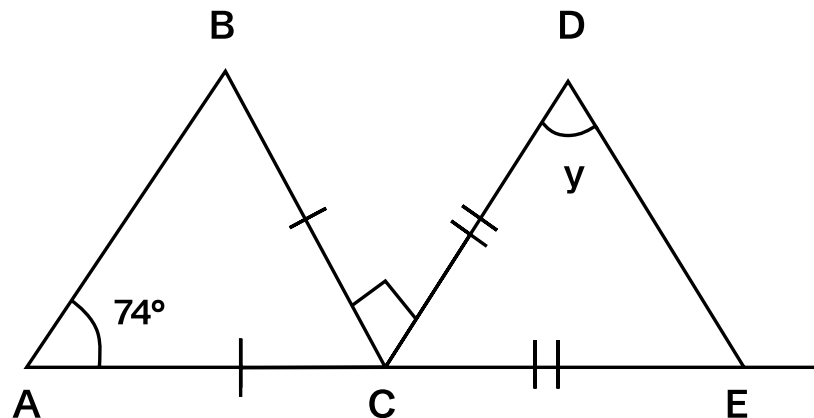
A 78° B 64.5° C 70° D 71.5° E 68°

25

The following distance-time graph shows the journey of a school bus.

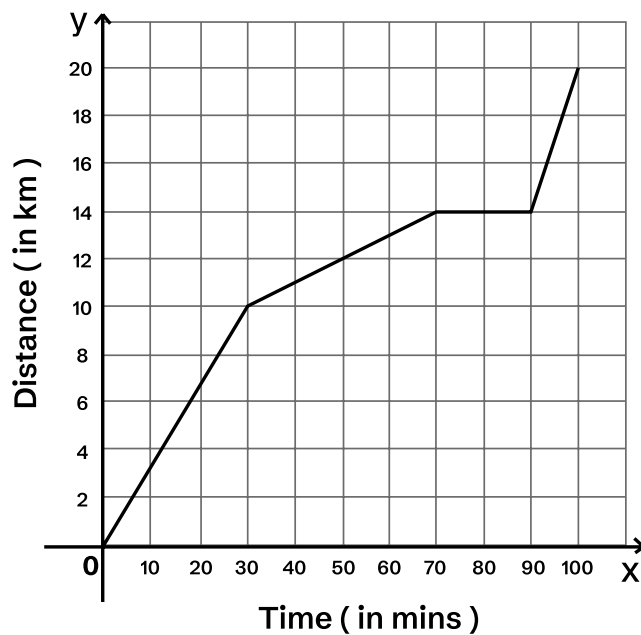

What is the speed of the school bus from 30 to 70 minutes ?

A 0.4 km/min

B 0.2 km/min

C 0.1 km/min

D 0.5 km/min

E 0.3 km/min

This is the end of the Test 2 - Maths.



© piacademy.co.uk - All rights reserved

Visit piacademy.co.uk/11-plus-papers to check the 'answers'

Kent Paper 1 Session 2

Answer Marking Sheet

Pupil's Name

School Name

Test Results	
Raw Score	<input type="text"/>
Standardized Score	<input type="text"/>
Marker's Initials	<input type="text"/>
Checker's Initials	<input type="text"/>

PUPILS REG, NUMBER									
<input type="text"/>	<input type="text"/>	<input type="text"/>	<input type="text"/>	<input type="text"/>	<input type="text"/>	<input type="text"/>	<input type="text"/>	<input type="text"/>	<input type="text"/>
[0]	[0]	[0]	[0]	[0]	[0]	[0]	[0]	[0]	[0]
[1]	[1]	[1]	[1]	[1]	[1]	[1]	[1]	[1]	[1]
[2]	[2]	[2]	[2]	[2]	[2]	[2]	[2]	[2]	[2]
[3]	[3]	[3]	[3]	[3]	[3]	[3]	[3]	[3]	[3]
[4]	[4]	[4]	[4]	[4]	[4]	[4]	[4]	[4]	[4]
[5]	[5]	[5]	[5]	[5]	[5]	[5]	[5]	[5]	[5]
[6]	[6]	[6]	[6]	[6]	[6]	[6]	[6]	[6]	[6]
[7]	[7]	[7]	[7]	[7]	[7]	[7]	[7]	[7]	[7]
[8]	[8]	[8]	[8]	[8]	[8]	[8]	[8]	[8]	[8]
[9]	[9]	[9]	[9]	[9]	[9]	[9]	[9]	[9]	[9]

DATE OF BIRTH		
Day	Month	Year
[0]	[0]	January <input type="checkbox"/> 1997 <input type="checkbox"/>
[1]	[1]	February <input type="checkbox"/> 1998 <input type="checkbox"/>
[2]	[2]	March <input type="checkbox"/> 1999 <input type="checkbox"/>
[3]	[3]	April <input type="checkbox"/> 2000 <input type="checkbox"/>
[4]	[4]	May <input type="checkbox"/> 2001 <input type="checkbox"/>
[5]	[5]	June <input type="checkbox"/> 2002 <input type="checkbox"/>
[6]	[6]	July <input type="checkbox"/> 2003 <input type="checkbox"/>
[7]	[7]	August <input type="checkbox"/> 2004 <input type="checkbox"/>
[8]	[8]	September <input type="checkbox"/> 2005 <input type="checkbox"/>
[9]	[9]	October <input type="checkbox"/> 2006 <input type="checkbox"/>
		December <input type="checkbox"/> 2007 <input type="checkbox"/>
		2008 <input type="checkbox"/>

Please mark boxes with a thin horizontal line like this  .



Test 1 - English

Reading Comprehension

1

PRACTICE

A

B

C

D

E

2

PRACTICE

A

B

C

D

E

1

A

B

C

D

E

2

A

B

C

D

E

3

A

B

C

D

E

4

A

B

C

D

E

5

A

B

C

D

E

6

A

B

C

D

E

7

A

B

C

D

E

8

A

B

C

D

E

9

A

B

C

D

E

10

A

B

C

D

E

11

A

B

C

D

E

12

A

B

C

D

E

13

A

B

C

D

E

Capital Letters and Punctuation Exercises

EXAMPLE

A

B

C

D

E

3

PRACTICE

A

B

C

D

E



14

A	<input type="checkbox"/>
B	<input type="checkbox"/>
C	<input type="checkbox"/>
D	<input type="checkbox"/>
E	<input type="checkbox"/>

15

A	<input type="checkbox"/>
B	<input type="checkbox"/>
C	<input type="checkbox"/>
D	<input type="checkbox"/>
E	<input type="checkbox"/>

16

A	<input type="checkbox"/>
B	<input type="checkbox"/>
C	<input type="checkbox"/>
D	<input type="checkbox"/>
E	<input type="checkbox"/>

Spelling Exercises

EXAMPLE

A	<input checked="" type="checkbox"/>
B	<input type="checkbox"/>
C	<input type="checkbox"/>
D	<input type="checkbox"/>
N	<input type="checkbox"/>

4

PRACTICE

A	<input type="checkbox"/>
B	<input type="checkbox"/>
C	<input type="checkbox"/>
D	<input type="checkbox"/>
N	<input type="checkbox"/>

17

A	<input type="checkbox"/>
B	<input type="checkbox"/>
C	<input type="checkbox"/>
D	<input type="checkbox"/>
N	<input type="checkbox"/>

18

A	<input type="checkbox"/>
B	<input type="checkbox"/>
C	<input type="checkbox"/>
D	<input type="checkbox"/>
N	<input type="checkbox"/>

19

A	<input type="checkbox"/>
B	<input type="checkbox"/>
C	<input type="checkbox"/>
D	<input type="checkbox"/>
N	<input type="checkbox"/>

20

A	<input type="checkbox"/>
B	<input type="checkbox"/>
C	<input type="checkbox"/>
D	<input type="checkbox"/>
N	<input type="checkbox"/>

Grammar Exercises

EXAMPLE

A	<input checked="" type="checkbox"/>
B	<input type="checkbox"/>
C	<input type="checkbox"/>
D	<input type="checkbox"/>
E	<input type="checkbox"/>

5

PRACTICE

A	<input type="checkbox"/>
B	<input type="checkbox"/>
C	<input type="checkbox"/>
D	<input type="checkbox"/>
E	<input type="checkbox"/>

6

PRACTICE

A	<input type="checkbox"/>
B	<input type="checkbox"/>
C	<input type="checkbox"/>
D	<input type="checkbox"/>
E	<input type="checkbox"/>

21

A	<input type="checkbox"/>
B	<input type="checkbox"/>
C	<input type="checkbox"/>
D	<input type="checkbox"/>
E	<input type="checkbox"/>

22

A	<input type="checkbox"/>
B	<input type="checkbox"/>
C	<input type="checkbox"/>
D	<input type="checkbox"/>
E	<input type="checkbox"/>

23

A	<input type="checkbox"/>
B	<input type="checkbox"/>
C	<input type="checkbox"/>
D	<input type="checkbox"/>
E	<input type="checkbox"/>

24

A	<input type="checkbox"/>
B	<input type="checkbox"/>
C	<input type="checkbox"/>
D	<input type="checkbox"/>
E	<input type="checkbox"/>

25

A	<input type="checkbox"/>
B	<input type="checkbox"/>
C	<input type="checkbox"/>
D	<input type="checkbox"/>
E	<input type="checkbox"/>



Test 2 - Maths

EXAMPLE

A

B

C

D

E

1 PRACTICE

A

B

C

D

E

2 PRACTICE

A

B

C

D

E

3 PRACTICE

A

B

C

D

E

1

A

B

C

D

E

2

A

B

C

D

E

3

A

B

C

D

E

4

A

B

C

D

E

5

A

B

C

D

E

6

A

B

C

D

E

7

A

B

C

D

E

8

A

B

C

D

E

9

A

B

C

D

E

10

A

B

C

D

E

11

A

B

C

D

E

12

A

B

C

D

E

13

A

B

C

D

E

14

A

B

C

D

E

15

A

B

C

D

E

16

A

B

C

D

E

17

A

B

C

D

E

18

A

B

C

D

E

19

A

B

C

D

E

20

A

B

C

D

E

21

A

B

C

D

E

22

A

B

C

D

E

23

A

B

C

D

E

24

A

B

C

D

E

25

A

B

C

D

E

For Parents use only

Marks Scored: Time taken:

Comments

.....

.....

.....



© piacademy.co.uk - All rights reserved

Visit piacademy.co.uk/11-plus-papers to check the 'answers'